

DAWN / DE-STA-CO COMPOSITE (NON METALLIC) CLAMPS

Manufactured from high strength glass reinforced nylon, which is light weight and has a high stability, electro-insulating and resistant against chemicals. These composite clamps were specially developed for light to medium duty applications in the chemical, electronics, wood, craft and model making industries.

Cantilever Clamps

Model CC1, CC2, CC3, CC4

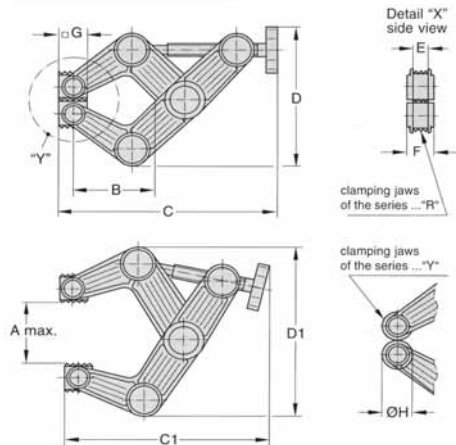

Features:

The hard and the soft rotatable clamping jaws of the series... R adapt to the workpiece when clamping jaws can be used both on their flat and on their notched side. The series... -Y comprises soft, round and rotatable clamping jaws for delicate workpiece surfaces.

Vertical Clamps

Model VH3

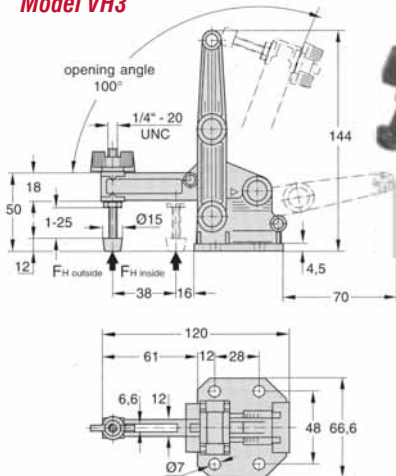

Model	Holding Capacity	Weight kg	Amax	B	C	C1	D	D1	E	F	G	ØH
VH3		65 kgs	0.1									
SL3		110 kgs	0.1									
BC6		70 kgs	0.4	0-150	335							
BC18		70 kgs	0.51	0-450	640							
BCBM6		70 kgs	0.4	0-150	270							
CC1-R & CC1-Y	4 kgs	0.01	22	19	50	55	32	42	2.5	6	6.5	8.5
CC2-R & CC2-Y	35 kgs	0.06	60	47	127	155	80	102	6	14.2	16	a20
CC3-R & CC3-Y	70 kgs	0.22	90	76	200	255	130	162	9.6	22.4	25	31
CC4-R & CC4-Y	100 kgs	0.71	140	114	300	390	190	243	14.2	33.2	38	47

Rack Clamps

Model BC6, BC18, BCBM6

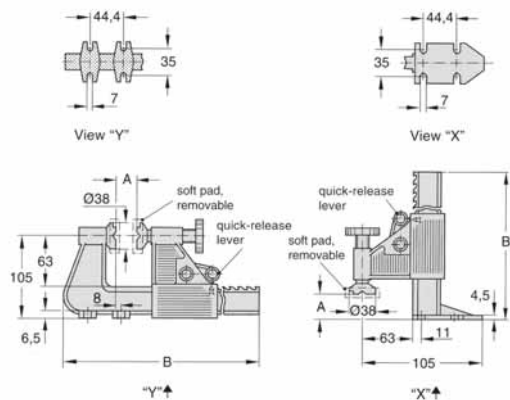

Operation

The clamp arm may be released from the rack by means of the quick release lever and locked in the desired clamping position within the range of the rack. These clamps exert their clamping force by means of their spindle hand wheel. The clamping plates are vee notched to hold round stock. The clamping plate of the clamp arm does not rotate during the clamping travel.

Straight-line Clamps

Model SL3

