

DE-STA-CO HOLD DOWN ACTION TOGGLE CLAMPS - HORIZONTAL HANDLE

Low silhouette series requiring minimum overhead clearance. All models come with bonded neoprene tipped spindle, lock nuts and flanged washers or bolt retainers.

Series 205, 215, 225, 235

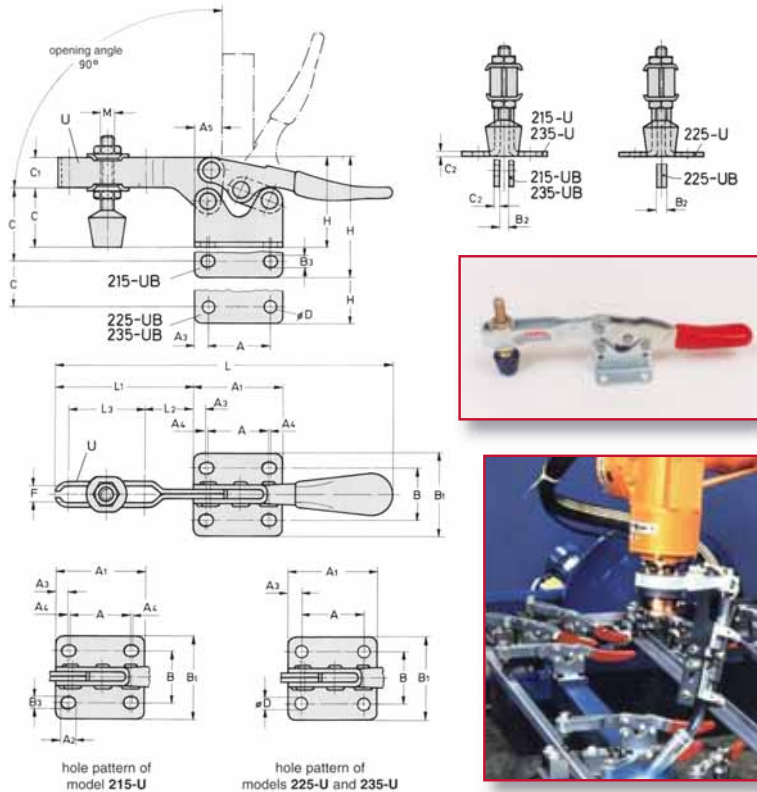

Series 213, 217, 227, 237, 245

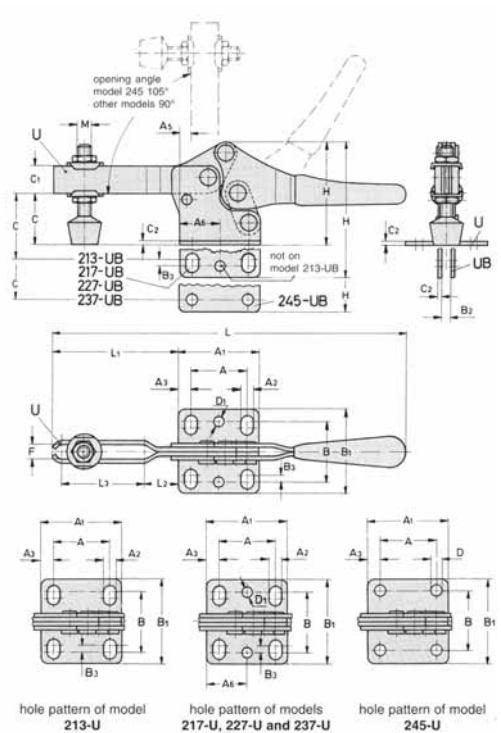

MODEL NO.	A	A1	A2	A3	A4	A5	A6	B	B1	B2	B3	C	C1	C2	ØD	ØD1	F	H	L	L1	L2	L3	M	HOLDING CAPACITY kg	WEIGHT kg
205-U	11.2	24	-	-	2.4	-	-	15.6	24	3	4.3	8	6.4	1.5	-	-	4.5	17	68	19	-	9.5	M4	25	0.03
205-UB	11.2	24	-	-	2.4	-	-	-	-	3	4.3	8	6.4	3	-	-	4.5	17	68	19	-	9.5	M4	25	0.03
205-UL	11.2	24	-	-	2.4	-	-	9.5	13.5	1.5	4.3	8	6.4	3	-	-	4.5	17	68	19	-	9.5	M4	25	0.03
205-USS	11.2	24	-	-	2.4	-	-	15.6	24	3	4.3	8	6.4	1.5	-	-	4.5	17	68	19	-	9.5	M4	25	0.03
205-S	11.2	24	-	-	2.4	-	-	15.6	24	3	4.3	9.5	3	1.5	-	-	-	17	71	21	-	-	M4	25	0.03
205-SB	11.2	24	-	-	2.4	-	-	-	-	3	4.3	9.5	3	3	-	-	-	17	71	21	-	-	M4	25	0.03
205-SR	11.2	24	-	-	2.4	-	-	9.5	13.5	1.5	4.3	9.5	3	3	-	-	-	17	71	21	-	-	M4	25	0.03
205-SL	11.2	24	-	-	2.4	-	-	9.5	13.5	1.5	4.3	9.5	3	3	-	-	-	17	71	21	-	-	M4	25	0.03
213-U	13.5	25.4	4.4	6	-	4.7	-	17.6	27	-	0.8	18.5	9.5	1.9	-	-	5.6	35.5	105	35.5	10	21.5	M5	70	0.07
213-UB	13.5	25.4	4.4	6	-	4.7	-	-	-	3.8	0.8	21.2	9.5	1.9	-	-	5.6	44	105	35.5	10	21.5	M5	70	0.07
213-USS	13.5	25.4	4.4	6	-	4.7	-	15.6	24	3	4.3	8	6.4	1.5	-	-	4.5	17	68	19	-	9.5	M4	70	0.07
215-U	25.5	37	5.9	5	0.8	11	-	22	35	4	5.1	25	13	2	-	-	7	38	141	57	20	32	M6	90	0.11
215-UB	25.5	37	5.9	5	0.8	11	-	-	4	5.1	30	13	2	-	-	-	7	50	141	57	20	32	M6	90	0.11
215-S	25.5	37	5.9	5	0.8	11	-	22	35	4	5.1	25	13	2	-	-	-	38	141	57	-	-	-	90	0.11
215-SB	25.5	37	5.9	5	0.8	11	-	-	4	5.1	30	13	2	-	-	-	-	50	141	27	-	-	-	90	0.11
217-U	26	37.4	5.5	5.7	-	6	18.5	28	38.6	-	3	24	13	2.5	-	4.8	6.4	49	164	58	15	38	M6	90	0.08
217-UB	26	37.4	5.5	5.7	-	6	18.5	-	5	3	30	13	2.5	-	4.8	6.4	63	164	58	15	38	M6	90	0.18	
217-USS	26	37.4	5.5	5.7	-	6	18.5	28	38.6	-	3	24	13	2.5	-	4.8	6.4	49	164	58	15	38	M6	90	0.18
225-U	25.4	38	-	6.5	-	13	-	22.2	35	-	-	35	13	3.2	6.5	-	9	48	171	69	26	36	M8	220	0.26
225-UB	25.4	38	-	6.5	-	13	-	-	-	-	-	35	13	3.2	6.5	-	9	48	171	69	26	36	M8	220	0.26
225-USS	25.4	38	-	6.5	-	13	-	22.2	35	-	-	35	13	3.2	6.5	-	9	48	171	69	26	36	M8	220	0.26
227-U	26	40	6.6	7	-	1	20	31	43.6	-	2.5	34	14	3	-	4.8	8.4	62	188	66	21	38	M8	220	0.30
227-UB	26	40	6.6	7	-	1	20	-	-	6	2.5	38	14	3	-	4.8	8.4	75	188	66	21	38	M8	220	0.30
227-USS	26	40	6.6	7	-	1	20	31	43.6	-	2.5	34	14	3	-	4.8	8.4	62	188	66	21	38	M8	220	0.30
235-U	41.2	57	-	8	-	17	-	41	57	8	-	45	19	4	8.1	-	10.5	64	264	103	35	60	M10	340	0.66
235-UB	41.2	57	-	8	-	17	-	-	-	8	-	59	19	4	8.1	-	10.5	86	264	103	35	60	M10	340	0.66
235-USS	41.2	57	-	8	-	17	-	41	57	8	-	45	19	4	8.1	-	10.5	64	264	103	35	60	M10	340	0.66
237-U	41	57	8.8	8	-	10	28.5	43	58	-	2	44.5	19	4	-	5.8	10.5	81	270	103	24	70	M10	340	0.75
237-UB	41	57	8.8	8	-	10	28.5	-	-	8	2	53.5	19	4	-	5.8	10.5	99	270	103	24	70	M10	340	0.75
237-USS	41	57	8.8	8	-	10	28.5	43	58	-	2	44.5	19	4	-	5.8	10.5	81	270	103	24	70	M10	340	0.75
245-U	41.5	67	-	12.5	-	-	-	41.5	67	-	-	57	25	5	8.5	-	13.5	108	312	125	36	77	M12	450	1.4
245-UB	41.5	67	-	12.5	-	-	-	-	-	9.5	-	65	25	5	8.5	-	13.5	128	312	125	36	77	M12	450	1.4

All dimensions in mm