

# "DAWN"

and "JAN" Products  
For the Workshop

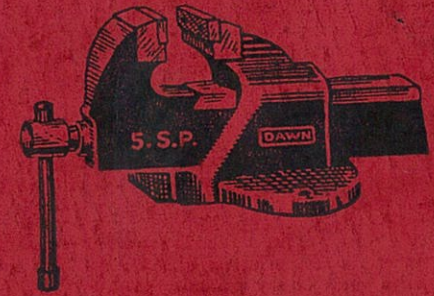

**GOLDEN ANNIVERSARY ISSUE**

1917

1967

FACTORY AND SALES OFFICE:

NORRIS STREET, NORTH COBURG, N.14  
VICTORIA, AUSTRALIA

# "DAWN"

and "JAN" Products  
For the Workshop



**GOLDEN ANNIVERSARY ISSUE**

1917

1967

FACTORY AND SALES OFFICE:

NORRIS STREET, NORTH COBURG, N.14  
VICTORIA, AUSTRALIA



RENOMA PRINTERY PTY. LTD. 205 Scotchmer St., North Fitzroy

TASMANIA and VICTORIA:

**HAROLD J. BEER PTY. LTD.,**  
232 King Street, Melbourne, Victoria, Australia.  
Phone: 67 6474 (Melbourne)  
Telegrams & Cables: "FANDAWN" Melbourne.

WEST AUSTRALIA:

**JOHN LEONARD PTY. LTD.,**  
Scarborough Beach Road, Osborne Park, West Australia.  
Phone: 24 1017 (Perth)  
Telegrams & Cables: "JOHNELL" Perth.

OVERSEAS

CANADA and U.S.A.:

**MacNAYS (CANADA) LIMITED,**  
1330 Frances Street, Vancouver 6BC, Canada.  
Phone: 3 7191 (Alpine)  
Telegrams & Cables: "ALLTOOLS" Vancouver.

MALAYA:

**J. E. TAN & COMPANY,**  
Room 103, Kwang Tung Building, 44 Puda Road,  
Kuala Lumpur, Malaya.  
Phone: 95856 (Singapore)  
Telegrams & Cables: "JETAN" Singapore.

NEW ZEALAND:

**H. LEIGHTON HILL LIMITED,**  
5 Vernon Street, Auckland, New Zealand.  
Phone: 40973 (Auckland)  
Telegrams & Cables: "LEIGHILL" Auckland.

PERU:

**PEDRO DEVOTO,**  
Ave. Petit Thouars No. 4737, Miraflores, Lima, Peru.  
Phone: 54 753 (Lima)  
Telegrams & Cables: "DEVOTO" Lima.

PHILIPPINES:

**SOLEX TOOL CORPORATION,**  
355 Barraca, Manila, Philippines.  
Phone: 20109 (Manila)  
Telegrams & Cables: "SOLEXTOOL" Manila.

SINGAPORE:

**J. E. TAN & COMPANY,**  
P.O. Box 1289, 123A Cecil Street, Singapore.  
Phone: 95856 (Singapore)  
Telegrams & Cables: "JETAN" Singapore.

THAILAND:

**THAI AUSTRAL TRADING LTD., PARTNERSHIP,**  
461 Nakorn-Swan Road, Bangkok, Thailand.  
Phone: 811210 (Bangkok)  
Telegrams & Cables: "NGOHMANU" Bangkok.

LEBANON:

**A. F. MALAAB,**  
Selim Takla Street, Beirut, Lebanon.  
Phone: 22 1811 (Beirut)  
Telegrams & Cables: "AFMALAAB"

ABBREVIATIONS AND EXPLANATIONS

"LP"	LIGHT PATTERN	"OS"	OFFSET
"SP"	STANDARD PATTERN	"CMPS"	CABINET MAKERS — PLAIN SCREW
"HP"	HEAVY PATTERN	"CMQA"	CABINET MAKERS — QUICK ACTION
"M"	MEDIUM PATTERN	"JWW"	JUNIOR WOODWORKERS
"QA"	QUICK ACTION		

Semi Steel Vices—Painted "Dawn" RED. All Steel Vices—Painted "Blue."

## RELIABLE "DAWN" PRODUCTS

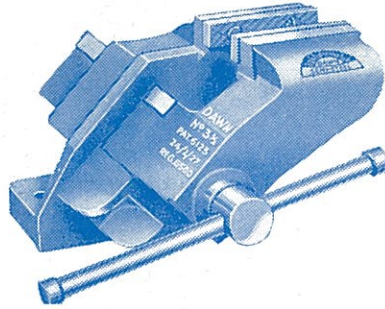

### OFF-SET VICES

(PLAIN SCREW)

(SEMI-STEEL)

This design has become very popular, because of the facility it provides for holding long vertical work with the full width of the jaws. The body and slide castings are of "DAWN" Semi-Steel, and the nut is replaceable. Made in six sizes.

#### THE SIZE DENOTES WIDTH OF JAWS

Size	Code No.	Max. Open.	Wght. Lbs.	Size	Code No.	Max. Open.	Wght. Lbs.
3"	9041	3 $\frac{1}{4}$ "	25	4 $\frac{1}{2}$ "	9044	6"	63
3 $\frac{1}{2}$ "	9042	4 $\frac{1}{4}$ "	34	5"	9045	6 $\frac{1}{2}$ "	85
4"	9043	5 $\frac{1}{2}$ "	54	6"	9046	7 $\frac{1}{2}$ "	114

## RELIABLE "DAWN" PRODUCTS

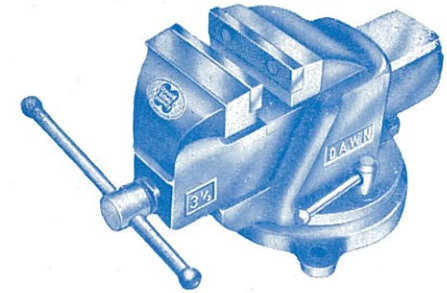

### SWIVEL BASE VICES

(PLAIN SCREW)

The sturdily constructed swivel base enables the operator to swing the vice to any desired lateral position where it can be readily locked with the two holding down screws. Made in nine sizes.

#### THE SIZE DENOTES WIDTH OF JAWS

Size	Code No.	Max. Open.	Wght. Lbs.	Size	Code No.	Max. Open.	Wght. Lbs.
2 $\frac{1}{2}$ "	9181	2 $\frac{3}{4}$ "	9	4 $\frac{1}{2}$ "SP	9185	5 $\frac{1}{2}$ "	51
3"	9182	3-3/8"	14 $\frac{1}{2}$	5"SP	9186	6-5/8"	66
3 $\frac{1}{2}$ "	9183	4-1/8"	25	6"SP	9187	7 $\frac{1}{2}$ "	88
4"LP	9188	4 $\frac{1}{4}$ "	26	8"HP	9190	10"	180
4"SP	9184	5 $\frac{1}{2}$ "	40				

## RELIABLE "DAWN" PRODUCTS

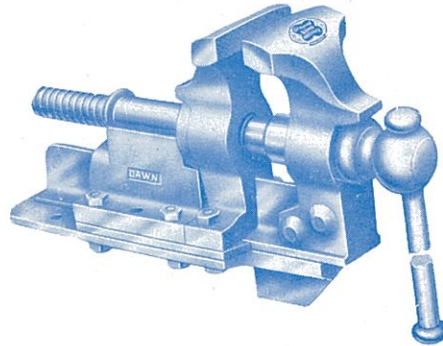

### STEEL "T" BAR VICES

Cast steel jaws with hardened serrated faces mounted on mild steel base plate, and mild steel "T" section slide bar.

#### THE SIZE DENOTES WIDTH OF JAWS

Size	Code No.	Max. Open.	Wght. Lbs.	Size	Code No.	Max. Open.	Wght. Lbs.
4"	9086	6"	56	7"	9089	10"	163
5"	9087	8"	80	8"	9090	11"	196
6"	9088	9"	124				

## RELIABLE "DAWN" PRODUCTS

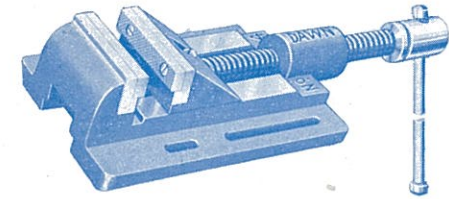

### MACHINE VICES

(SEMI-STEEL)

Fitted with plain screw. This type of vice for machine shop use has accurately machined slide faces, and is equipped with hardened steel parallel jaws. The bottom of base is machined and slots are provided for holding down bolts.

#### THE SIZE DENOTES WIDTH OF JAWS

Size	Code No.	Maximum Opening	Height of Jaws	Weight Lbs.
3½"	9081	2½"	1-1/16"	9½
4"	9082	4-5/8"	1-7/16"	24
5"	9083	10"	1¾"	44

RELIABLE "DAWN" PRODUCTS

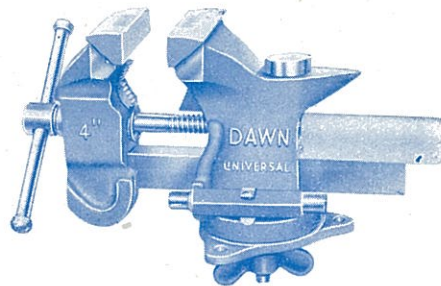

★ UNIVERSAL VICE

(Code No. 9189)

This vice is ideally suited for Garage use as well as for the Home craftsman.

Width of Jaw	.....	.....	.....	.....	4"
Maximum Opening	.....	.....	.....	.....	4½"
Weight	.....	.....	.....	.....	21 lbs.

Pipe Jaws will hold up to 1½" outside diameter.

FEATURES:— Vice will swivel full 360° - Offset Jaws to take work vertically - Hardened steel Anvil - High tensile steel Slide - Pipe Grips with hardened Steel Jaw - Tubing and Rod Bender - Cylinder Head Holding Plug for use when Valve Grinding, etc. (Screwed English and American Plug Threads) - Clip on plastic Jaws to obviate marking precision work - Finished "Dawn" Gloss Red - Vice carries usual "Dawn" Guarantee as to material and workmanship.

RELIABLE "DAWN" PRODUCTS

★ 4" FILERS VICE

Code No. 9015

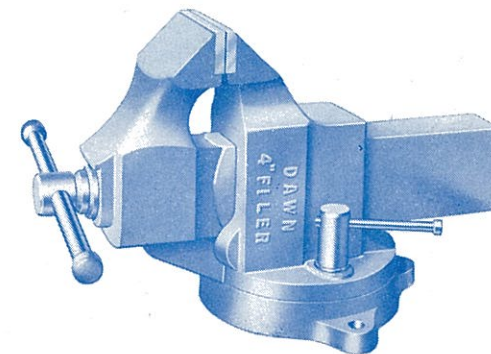

Width of Jaw—4". Opening—5¼". Angle of Jaws 40° makes this Vice ideally suited for Tool Room use. Nut—Dovetailed, Malleable Iron. Smooth Detachable Jaws—Tool Steel—hardened and ground.

Height from top of Slide to Tip of Jaw—3-5/8".

Body—Fully Broached.

Slide—Completely Machined. } allowing Full Slide Bearing

for Precision Holding. Full—360° Swivel with Machined Base. Weight—52 lbs. Finished—"DAWN" Gloss Red.

Fully guaranteed against Faulty Material and Workmanship.

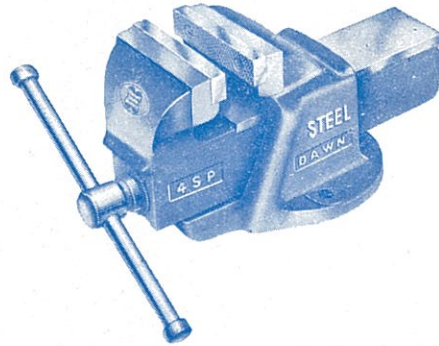

★ **SOLID CAST STEEL VICES**  
(PLAIN SCREW)

These vices are recommended for particularly hard usage. They are made of electric steel castings and are unbreakable. The plain screw range is made in four sizes.

THE SIZE DENOTES WIDTH OF JAWS

Size	Code No.	Maximum Opening	Weight, Lbs.
4"	9051	5½"	30
4½"	9052	5-5/8"	36
5"	9053	6-5/8"	49
6"	9054	7½"	64

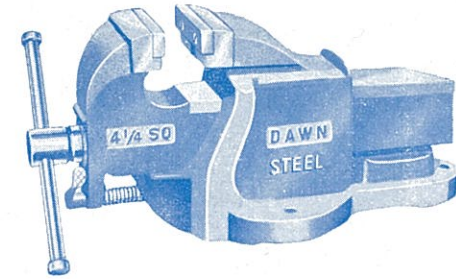

★ **SOLID CAST STEEL VICES**  
(QUICK ACTION)

Made in three standard sizes. These vices are constructed with the same unbreakable qualities as the plain screw, but the quick release enables rapid adjustment for holding various sizes of work.

THE SIZE DENOTES WIDTH OF JAWS

Size	Code No.	Maximum Opening	Weight, Lbs.
4½"	9061	6-7/8"	56
5½"	9062	7½"	69
6"	9063	8¾"	84

## RELIABLE "DAWN" PRODUCTS



### SOLID CAST STEEL OFFSET VICES

A popular Vice for use in industry because of the facility provided for holding long vertical work with the full width of jaws. The solid electric castings give positive grip without springing

Made in four sizes.

#### THE SIZE DENOTES WIDTH OF JAWS

Size	Code No.	Maximum Opening	Weight, Lbs.
4"	9071	6½"	57
4½"	9072	6¾"	63
5"	9073	6¾"	74
6"	9074	7"	103

## RELIABLE "DAWN" PRODUCTS

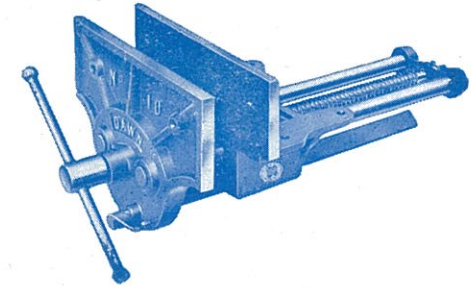

### ★ WOODWORKERS VICES

(QUICK ACTION AND PLAIN SCREW)

These Vices are designed with generous jaw area and are the approved standard for wood-workers' use. The slide bars are of ample proportioned bright steel, running in accurately bored guide holes. The quick action type provides for speedy operation on work of varying dimensions. Both the quick-action and plain screw are made in four sizes.

#### THE SIZE DENOTES WIDTH OF JAWS

Size	Code No.		Maximum Opening
	Plain Screw	Quick Action	
7"	9132	9136	9"
8"	9133	9137	9"
9"	9134	9138	12"
10"	9135	9139	12"



## RELIABLE "DAWN" PRODUCTS

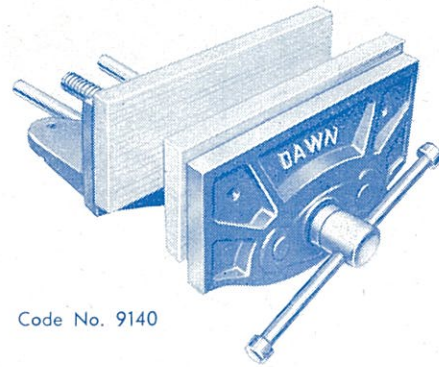

Code No. 9140

### HOME CARPENTER VICE KIT

Features of this product are as follows:-

6" Width of Jaw, 6" Opening, 2 $\frac{1}{4}$ " Depth of Jaw, Weight, 6 $\frac{1}{2}$  lbs. - Nickel-plated Slide Bars and Screw - Spring-Loaded Screw - Four screw holes for mounting under Bench - Two Wooden Jaw Liners Supplied - Eight Countersunk Screws supplied in plastic container - "Dawn" Red Baked Enamel Gloss Finish - Individually boxed. Packed Six to Master Carton - All parts interchangeable - Vice carries usual "Dawn" guarantee.

## RELIABLE "DAWN" PRODUCTS

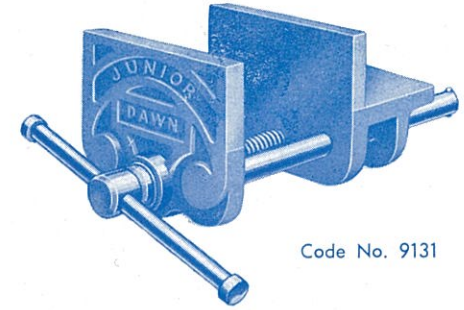

Code No. 9131

### JUNIOR WOODWORKERS VICES

(PLAIN SCREW)

The "Dawn" Junior is very strongly designed, and is constructed with the same precision as the larger standard woodworkers' vices. The slide bars are of bright mild steel, running in accurately bored guide holes. Machine cut screw and replaceable nut. This vice is built to stand hard work and is admirably suited to the use of the home carpenter. It is also a very popular and useful Xmas or Birthday present for the growing boy.

Width of Jaw	5 inches
Depth of Jaw	2 $\frac{1}{2}$ inches
Maximum Opening	7 inches
Weight	9 pounds

## RELIABLE "DAWN" PRODUCTS

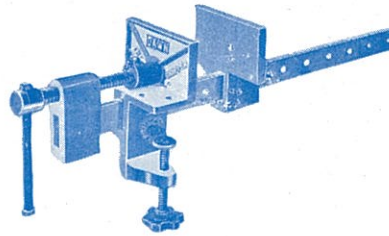

### GRIPPER VICES

(COMBINED VICE AND SASH CRAMP)

This combination is pronounced by carpenters and joiners to be one of the handiest tools on the bench, and is particularly adapted for the home-craftsman. It can be cramped on almost anywhere—the kitchen table, bench, stool or rail. The jaws are 5" wide and 3" deep. Made in five standard lengths, but longer bars can be supplied to order.

Size	Code No.	Size	Code No.
24" bar	9141	42" bar	9144
30" bar	9142	48" bar	9145
36" bar	9143		

## RELIABLE "DAWN" PRODUCTS



### JOINERS CRAMPS

(TEE BAR SECTION)

(Made in two Patterns—Light and Heavy)

The T Section Bars are of steel especially rolled for the purpose, the jaw edges brightly polished. The malleable fittings have been given increased length, and attention is drawn to the extra heavy section around the T slot of the jaw castings, where the strain is greatest.

#### SIZE DENOTES OVERALL MEASUREMENT

Size	Code No.		Max. Open.	Size	Code No.		Max. Open.
	Light	Heavy			Light	Heavy	
24"	9231	9251	18"	72"	9239	9259	66"
30"	9232	9252	24"	78"	9240	9260	72"
36"	9233	9253	30"	84"	9241	9261	78"
42"	9234	9254	36"	90"	9242	9262	84"
48"	9235	9255	42"	96"	9243	9263	90"
54"	9236	9256	48"	102"	—	9264	96"
60"	9237	9257	54"	108"	—	9265	102"
66"	9238	9258	60"				

## RELIABLE "DAWN" PRODUCTS

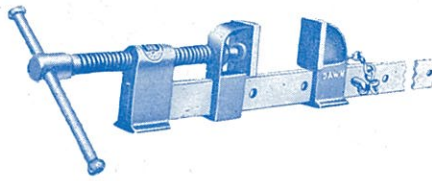

### JOINERS CRAMPS

(RECTANGULAR BAR SECTION)

(Made in two Patterns—Light and Heavy)

With bright steel bar (Light Pattern  $1\frac{1}{4}$ " x  $\frac{1}{4}$ " section Heavy Pattern  $1\frac{1}{2}$ " x  $5/16$ " section); best malleable fittings; the nut and sliding box sections are of an extra length to provide easy action with increased strength and rigidity, mild steel machined screw and handle.

SIZE DENOTES OVERALL MEASUREMENT

Size	Code No.		Max. Open.	Size	Code No.		Max. Open.
	Light	Heavy			Light	Heavy	
24"	9280	9300	18"	48"	9284	9304	42"
30"	9281	9301	24"	54"	9285	9305	48"
36"	9282	9302	30"	60"	9286	9306	54"
42"	9283	9303	36"				

## RELIABLE "DAWN" PRODUCTS

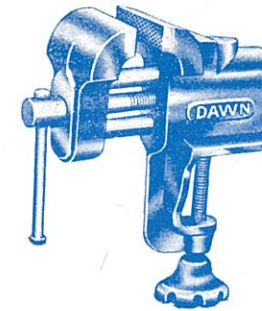

### STEEL GUIDE VICES

Width of Jaw, 2"

Max. Opening, 2"

Weight,  $3\frac{1}{2}$  lbs.

Code No, 9340

### DAWNETTE

Width of Jaw, 2"

Maximum Opening, 2"

Weight, 3 lbs.

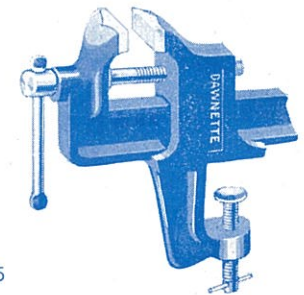

Code No, 9345

## RELIABLE "DAWN" PRODUCTS

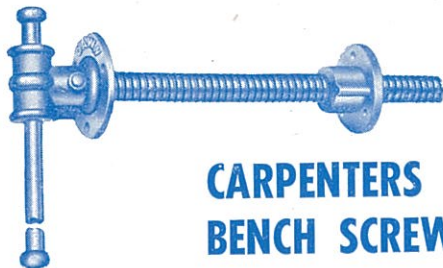

### CARPENTERS BENCH SCREWS

The screw and handle are of best mild steel, with particularly sturdy fittings. Attention is drawn to the strong full circle thrust flange on the nut.

Diameter of Screw	Code No.	Length from Collar	Length of Thread
1"	9150	16"	13"
1-1/8"	9151	16"	13"
1 1/4"	9152	16"	13"

### CRAMP HEAD FITTINGS

These fittings can be readily mounted by the user on a 2" x 1" or 3" x 1" hardwood batten of any length, thereby providing a cramp of whatever capacity is desired.

Size of Jaws,  
1 3/4" x 1 5/8"

Code No. 9205



22

## RELIABLE "DAWN" PRODUCTS

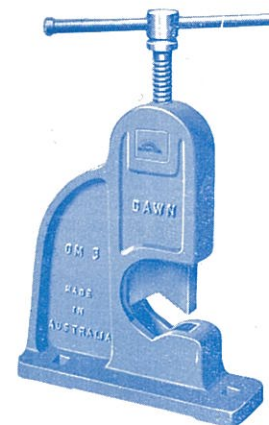

### PIPE VICES (OPEN MOUTH TYPE)

This heavy pattern pipe vice is cast in "Dawn" Semi-Steel, and is amply proportioned for hard use. A feature of the "Dawn" design is the replaceable nut, which adds to the life of the vice. The sliding jaw is of cast-steel with machine cut hardened teeth.

Made in four sizes.

Size	Code No.	Takes Pipe to	Weight, Lbs.
OM 1	9111	1 1/2" dia	18
OM 2	9112	2" dia.	38
OM 3	9113	3" dia.	50
OM 4	9114	4" dia.	89

23

## RELIABLE "DAWN" PRODUCTS

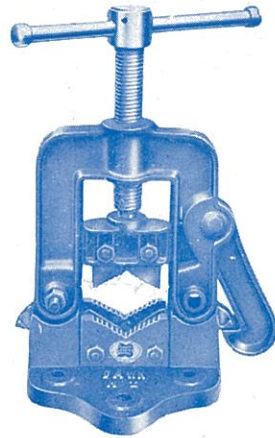

### PIPE VICES

(HINGE TYPE)

Malleable iron castings, self-locking frame and hardened steel jaws.

Made in three sizes.

Size	Code No.	Takes Pipe to
H2	9121	2" dia.
H2½	9122	2½" dia.
H4½	9123	4½" dia.

24

## RELIABLE "DAWN" PRODUCTS

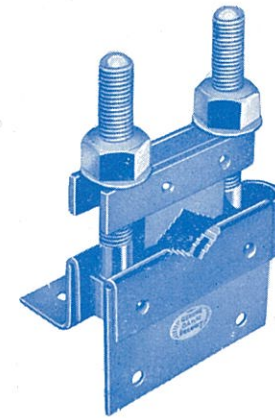

### PIPE VICES

(POST TYPE)

Particularly suitable for inclusion in the plumber's tool kit, this design is made of pressed steel with hardened steel jaws—light, compact and strong.

Made in three sizes.

Size	Code No.	Takes Pipe to
P.1	9091	1½" dia.
P.2	9092	2" dia.
P.3	9093	3" dia.

25

## RELIABLE "DAWN" PRODUCTS

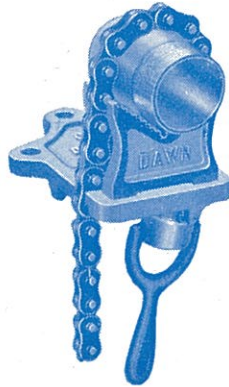

### PIPE VICES

(CHAIN TYPE)

This sturdy compact design is a very popular plumber's tool. Cast steel, machine cut hardened jaws. Grips firmly and is speedily operated. Made in three sizes.

Size	Code No.	Takes Pipe to	Weight, Lbs.
C.2	9101	2" dia.	4
C.4	9102	4" dia.	10
C.6	9103	6" dia.	19

26

## RELIABLE "DAWN" PRODUCTS



### MALLEABLE "G" CLAMPS

Dawn "G" Clamps are of a deep throated heavy section design for strength and rigidity. Machine cut screw with swivel button. Attractively finished for display purposes in bright "Dawn" red.

SIZE DENOTES OPENING

Size	Code No.	Centre of Screw to Back	Size	Code No.	Centre of Screw to Back
2½"	9210	1¾"	6"	9214	2¾"
3"	9211	1¾"	8"	9215	3-3/8"
4"	9212	2"	10"	9216	3-7/8"
5"	9213	2-5/8"	12"	9217	4-3/8"

27

## RELIABLE "DAWN" PRODUCTS

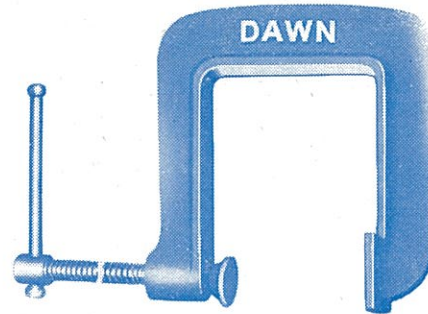

(Code No. 9221)

### DEEP THROATED CLAMP

(D. 4)

Specially designed for Boat Building, Boilermaking, Truck Body Building, etc., where a Deep Throated Clamp is required.

- ★ Steel Casting of heavy Section.
- ★ Machine Cut Screw with Swivel Button.
- ★ Size denotes Maximum opening in inches.
- ★ Depth from centre of Screw to back, 6 $\frac{1}{4}$ ".
- ★ Attractive "Dawn" Gloss Red Finish.
- ★ WEIGHT—6 lbs.

28

## RELIABLE "DAWN" PRODUCTS

### QUICK ACTION CLAMPS

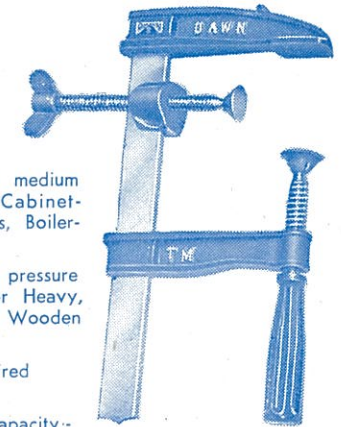

\*A very useful clamping medium used by Carpenters, Cabinet-makers, Engineers, Welders, Boiler-makers, etc.

\*A self Locking Tool with pressure adjustable, either Light or Heavy, by unbreakable Plastic or Wooden Handle Grip.

\*Instant adjustment to required capacity.

\*Size of Clamp indicates capacity:-

TYPE AND CODE No.

6" T.L. (9361) — 8" T.L. (9362)

With 1" x  $\frac{3}{4}$ " Bright Steel Bar with Bevelled and Serrated edge.

9"TM	10"TM	12"TM	15"TM	18"TM	20"TM	24"TM
9363	9360	9364	9365	9366	9367	9368

With 1 $\frac{1}{4}$ " x 5/16" Bright Steel Bar as above.

Dawn Red enamelled finish.

\*Individually cartoned in attractive Boxes with illustrations of Clamp on front and usages on back. Labelled each end for shelf display.

\***E.M. ATTACHMENT** (Extension Medium) illustrated, attached to Steel Bar of Clamp for use when pressure is required at right angle to Clamping pressure. Fits T.M. Clamps only. (Code 9371).

29

## RELIABLE "DAWN" PRODUCTS

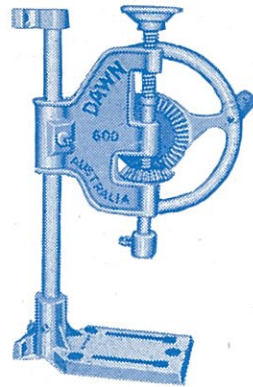

### ★ DRILLING MACHINES

(COMBINED BENCH OR POST)

No. 600

Code No. 9155

This sturdy little machine is designed to be fixed to either bench or post, and is admirably suited for the home work-shop, both in efficiency and price. The head has radial and vertical adjustment and gives a maximum clearance of 10 inches between base and end of spindle. Hand feed.

Drills to Centre .....	9" Circle
Drills Holes to .....	$\frac{3}{4}$ " dia.
Run of Feed .....	2"
Diameter of Spindle .....	$\frac{3}{4}$ "
Diameter of Pillar .....	1"
Height of Pillar .....	20"
Base .....	7" x 5"
Chuck Bored for $\frac{1}{2}$ " Straight Shank.	
Weight .....	29 lbs.

## RELIABLE "DAWN" PRODUCTS

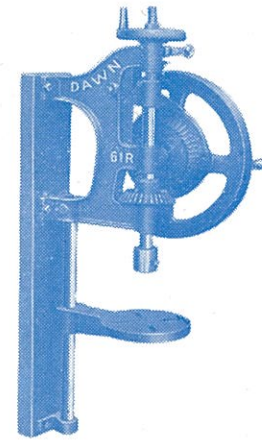

### DRILLING MACHINES

(POST TYPE)

(With Flywheel fitted to Main Spindle)

No. 61R

Code No. 9156

This is a well-constructed, light type drilling machine, fitted with adjustable automatic feed. The main spindle assembly is identical with that of the "DAWN" No. 611, featuring the "Improved Dawn Coupler and Ball Bearing Thrust." The Flywheel is of particularly heavy design to maintain momentum.

Drills to Centre .....	12" Circle
Drills Holes to .....	1" dia.
Run of Feed .....	3"
Run of Table .....	11"
Diameter of Spindle .....	$\frac{7}{8}$ "
Diameter of Pillar .....	1"
Chuck Bored for $\frac{1}{2}$ " Straight Shank.	
Weight .....	51 lbs.



★ **DRILLING  
MACHINES**

(POST TYPE, WITH GEAR  
DRIVEN FLYWHEEL)

No. 611

Code No. 9157



Ruggedly constructed, with accurately reamed bearings. The coupling between the main spindle and feed screw engages the full circumference of the spindle, and embraces a ball-bearing thrust race. The pillar, as in all "Dawn" Drilling Machines, is a solid bright steel bar in place of the usual light tubing. Adjustable automatic feed.

F. & L. Pulleys extra if required.  
(Pulley diameter, 6" x 1½" face)  
Maximum Speed, 200 r.p.m.

Drills to Centre	.....	.....	.....	.....	.....	12" Circle
Drills Holes to	.....	.....	.....	.....	.....	1½" dia.
Run of Feed	.....	.....	.....	.....	.....	3"
Run of Table	.....	.....	.....	.....	.....	11"
Diameter of Spindle	.....	.....	.....	.....	.....	7/8"
Diameter of Pillar	.....	.....	.....	.....	.....	1-1/8"
Chuck Bored for ½" Straight Shank.	.....	.....	.....	.....	.....	
Weight	.....	.....	.....	.....	.....	65 lbs.

★ **DRILLING  
MACHINES**

(BENCH TYPE)

No. 611

Code No. 9158

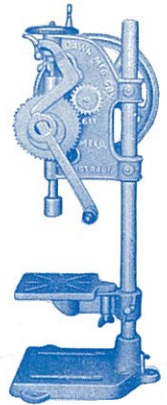

This machine is of the same capacity as the 611 Post Type, but fitted with a wide slotted base for bolting to the bench, and heavy back pillar.

Drills to Centre	.....	.....	.....	.....	.....	12" Circle
Drills Holes to	.....	.....	.....	.....	.....	1½" dia.
Run of Feed	.....	.....	.....	.....	.....	3"
Run of Table	.....	.....	.....	.....	.....	11"
Diameter of Spindle	.....	.....	.....	.....	.....	7/8"
Diameter of Pillar	.....	.....	.....	.....	.....	1½"
Chuck Bored for ½" Straight Shank.	.....	.....	.....	.....	.....	
Weight	.....	.....	.....	.....	.....	82 lbs.

**DRILLING MACHINES**

(POST TYPE, Ball Bearing Automatic Feed)

No. 616

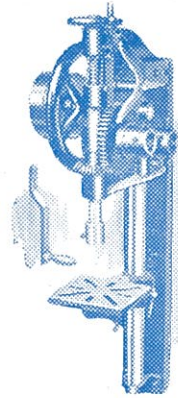

Code No. 9161

A heavier type of machine, geared for two speeds.

Fast and loose pulleys for belt drive are extra, and only supplied when specified.

Maximum speed, 200 r.p.m.

Drills to Centre	.....	.....	.....	.....	16" Circle
Drills Holes to	.....	.....	.....	.....	1½" dia.
Run of Feed	.....	.....	.....	.....	3½"
Run of Table	.....	.....	.....	.....	15"
Diameter of Spindle	.....	.....	.....	.....	1-1/8"
Diameter of Pillar	.....	.....	.....	.....	1½"
Chuck Bored for ½" Straight Shank.	.....	.....	.....	.....	
Weight	.....	.....	.....	.....	126 lbs.



**LIFTING JACKS**

(BROAD BASE, LOW LIFT)

Size	3 ton	6 ton
Minimum Height	9½"	9"
Maximum Height	13½"	12½"
Diameter of Screw	1¾"	2"
Diameter of Base	7"	8½"
Weight	19 lbs.	30 lbs.
Code No.	9325	9326

## RELIABLE "DAWN" PRODUCTS

### ★ LIFTING JACKS

(NARROW BASE, HIGH LIFT)

Size	1 Ton	3 Ton	5 Ton	10 Ton
Min. Height	9"	15"	20"	24"
Max. Height	13"	24"	29"	36"
Dia. of Screw	1-1/8"	1-5/8"	1 3/4"	2"
Dia. of Base	4 1/2"	7"	7"	7"
Weight	8 3/4 lbs.	27 lbs.	39 lbs.	56 lbs.
Code No.	9320	9321	9322	9323



10 Ton



(NARROW BASE, LOW LIFT)

Size	3 Ton
Min. Height	6 1/4"
Max. Height	8 3/4"
Dia. of Screw	1-5/8"
Dia. of Base	4 1/2"
Weight	8 lbs.
Code No.	9324

## RELIABLE "DAWN" PRODUCTS

### GRINDING AND POLISHING HEADS

No. 22



(Code No. 9171)

No. 22—Double polishing spindle and one set of flanges for 3/4" thick grinding wheel.

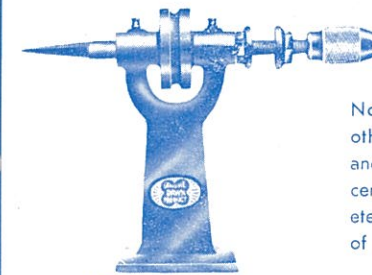

No. 24

No. 24—Single polisher; other end with pair of flanges and drill chuck. Height to centre of spindle, 6". Diameter of spindle, 3/8". Diameter of pulley, 2 1/4".

(Code No. 9172)

## RELIABLE "DAWN" PRODUCTS



### GRINDING AND POLISHING HEADS

(Code No. 9173) No. 26

No. 26—Double end grinding spindle. Two sets of flanges to take  $\frac{3}{4}$ " thick grinding wheels.



No. 28

(Code No. 9174)

Double end grinding and Polishing spindle. Two sets of flanges for  $\frac{3}{4}$ " thick wheels.

Height to centre of spindle, 6". Diameter of spindle,  $\frac{1}{2}$ ". Diameter of Pulley,  $2\frac{1}{4}$ ".

38

## RELIABLE "DAWN" PRODUCTS



(Code No. 9200)

### EMERY DRESSER HANDLE

This medium Pattern Emery Dresser Handle is recommended for general purpose wheel dressing, where it is essential to keep the wheel face open. Designed to take Standard No. "O" Dresser Wheels. "Dawn" Red Gloss finish. Weight, 2 lbs.

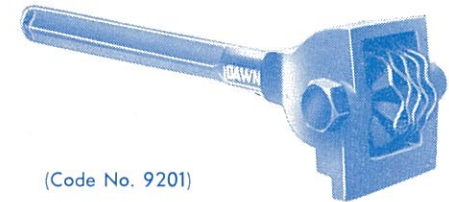

(Code No. 9201)

### HEAVY DUTY EMERY DRESSER (COMPLETE)

Rugged Cast Body and Handle, with corrugated high quality hardened Steel Cutters, running on special hardened Steel Spindle. This mechanical Dresser is provided with a special rest for use on a Grinding Wheel which has become oval. Attractive "Dawn" Red Gloss finish. Weight,  $6\frac{1}{2}$  lbs.

Spare H.D. Wheels for above (Sets of 5) — Code No. 9202.

39

## RELIABLE "DAWN" PRODUCTS

### CLOTHES LINE HOIST

(SEMI-STEEL)

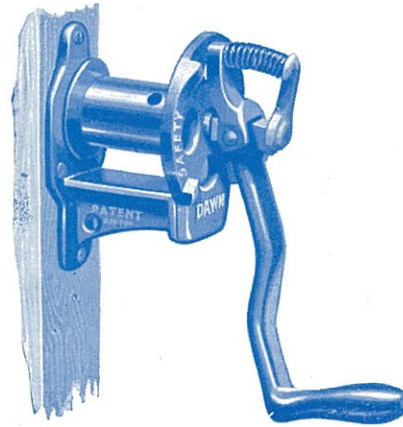

Code No. 9194

Diameter of drum	.....	.....	.....	2"
Length of drum	.....	.....	.....	2½"
Outside diameter of flange	.....	.....	.....	2¾"
Weight	.....	.....	.....	6½ lbs.

This handy little Ratchet Hoist was originally designed for raising clothes lines. Recently, however, further applications have emerged such as lifting Theatre Curtains and television antennas. Finished in Gloss Green.

## RELIABLE "DAWN" PRODUCTS



### PORTABLE VICE BENCHES

Code No. 9130

This is a popular and time saving item of Garage and Workshop equipment. The triangular base is fitted with rollers at the two forward extremities, and by tilting forward the bench can be readily wheeled to any desired position alongside the job. The blunt peg under the rear point of the base effects a steady foundation. The bench is wholly constructed of best grey cast iron and weighs 120 lbs. The table dimensions are 24" x 12"

## RELIABLE "DAWN" PRODUCTS

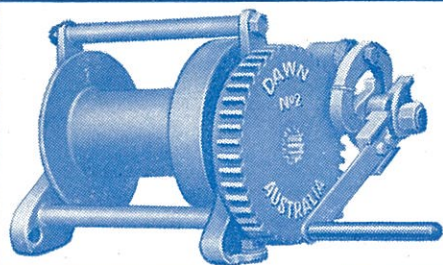

### ALL STEEL HAND WINCHES

	No. 1	No. 2	No. 5
Capacity -	10 Cwts.	S.W.L. ★25 Cwts	S.W.L. ★55 Cwts
Material of winch	Steel 45 Ton	Steel 45 Ton	Steel 45 Ton
Diameter of Drum	3½"	4"	5-5/8"
Length of Drum	6"	8"	10"
Speed Ratio—High	Direct on D/Shaft	☆4 to 1	☆4.3 to 1
—Low	4.2 to 1	22 to 1	24 to 1
Drum Capacity	80 Ft.	120 Ft.	250 Ft.
Rope Diameter	5/16"	3/8"	9/16"
Rope Construction	6/26 WF IWRC	6/26 WF IWRC	6/26 WF IWRC
Weight - Lbs.	40 Lbs.	76 Lbs.	134 Lbs.
Approx. Dimen. - Excl. Handle.	12" x 9" x 9"	15" x 13" x 11"	20" x 17" x 15"
Effort required - on Handle to raise Full Load.	40 Lbs.	37 Lbs.	39 Lbs.

★ Above capacities are governed by a single fall of rope, however safe working load can be increased by different pulley block arrangements.

☆ For use with High Speed Ratio, additional pinion and extension Shaft is required.

## RELIABLE "DAWN" PRODUCTS

### ★ ALL STEEL HAND WINCHES

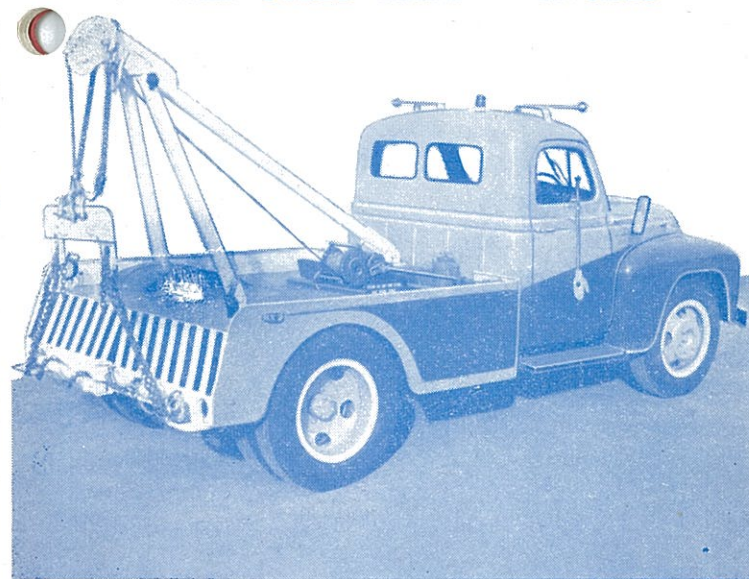

This illustration is a typical winch mounting on a tow-truck. No. 2 and No. 5 Winches are fitted with an Automatic Safety Load Brake which applies, whilst under load, immediately the operator releases the winding handle. Provision is also made for extending the handle to enable the winch to be operated from side of vehicle.

FULLY APPROVED FOR MOUNTING ON VEHICLES

## RELIABLE "DAWN" PRODUCTS

Illustrated are a few of the vast range of "DAWN" Fans.

Pressure Blowers —

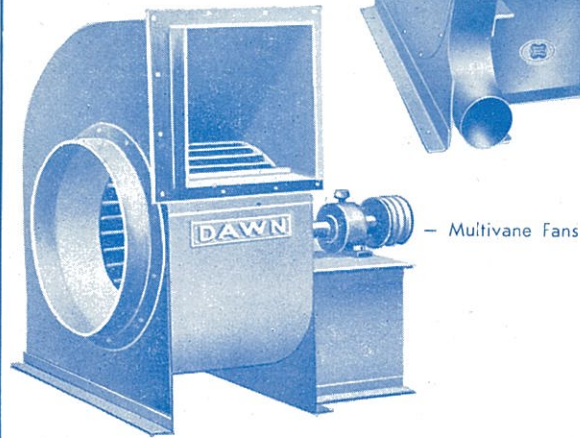
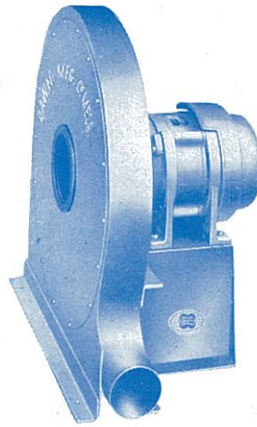

— Multivane Fans

44

## RELIABLE "DAWN" PRODUCTS

Axial  
Flow  
Fans

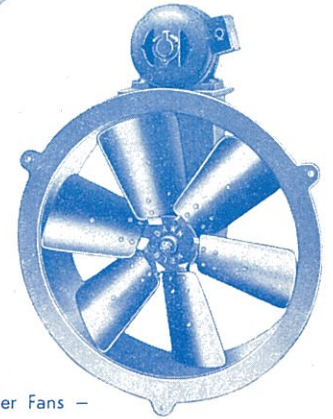
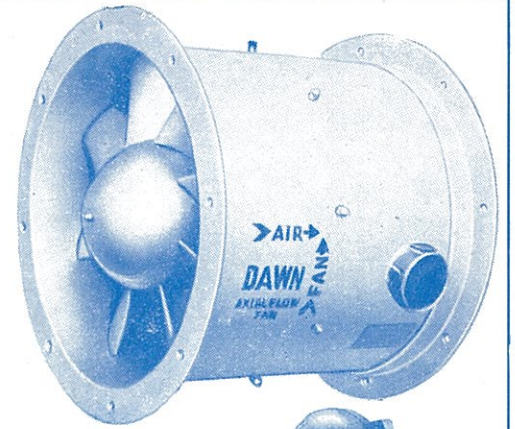

Enclosed Propeller Fans —

45

## RELIABLE "DAWN" PRODUCTS

Cast Iron Exhaust Fan

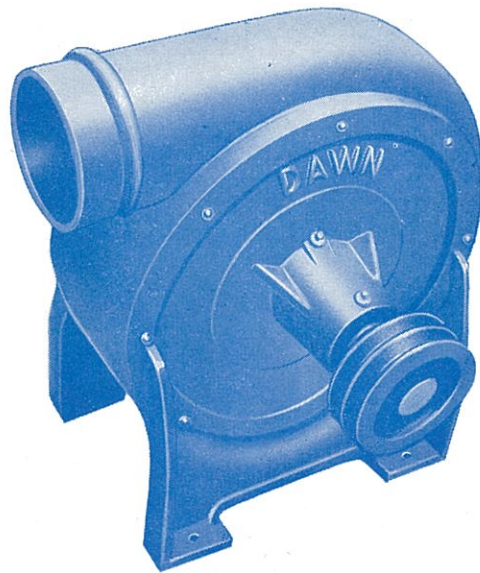

46

## RELIABLE "JAN" PRODUCTS

### ★ RATCHET SCREWING SETS



No. 26 (Code 4026)  $\frac{1}{2}$ " -  $\frac{3}{4}$ "BSP Weight 9 Lbs.  
No. 27 (Code 4027)  $\frac{1}{2}$ " -  $\frac{3}{4}$ " - 1"BSP Weight 11 Lbs.  
(Packed in Cartons)

- Acclaimed by plumbers throughout Australia as the most accurate, easiest-to-operate, lightweight and compact pipe threader available.
- Ideal for close corners . . . will cut really smooth, clean threads quickly and accurately even with swinging space reduced to 30°.
- Engineered chaser dies make for cleaner threads with half the effort.
- Chaser dies can be sharpened quickly-accurately-for repeated use over many years.

47



## RELIABLE "JAN" PRODUCTS

### ★ RATCHET SET

(SQUARE BLOCK TYPE)

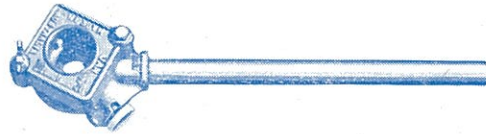

No. 25 (Code 4025) Block Type  $\frac{1}{2}$ "- $\frac{3}{4}$ "-1" BSP Weight 8 Lbs.  
also suitable for American Block Dies.

48

## RELIABLE "JAN" PRODUCTS

### ★ PIPE CUTTER

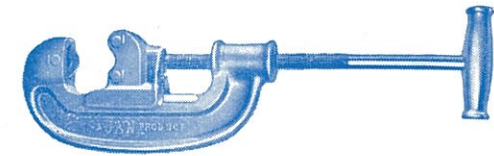

No. 28 (Code 4028) Weight 3 $\frac{1}{2}$  Lbs.

28/6 Spare Wheels readily available (Packed in 1 Doz. lots).

#### HEAVY DUTY PIPE CUTTER

A  $\frac{1}{2}$ "-2" capacity tool, designed and built to withstand continuous, gruelling hard work. Extra strong magnesium alloy construction and hardened steel thread insert make light work of heavy cutting.

FULLY GUARANTEED.

49

## RELIABLE "JAN" PRODUCTS

### ★ TUBE CUTTER

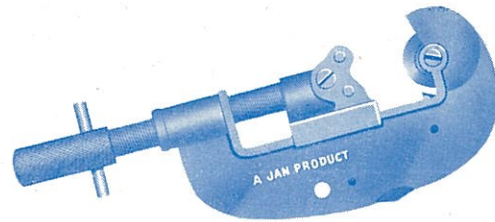

No. 49 (Code 4049) Weight 4 ozs.  
No. 49/6 Spare Wheels (Packed in 1 Doz. Lots).

#### LIGHT DUTY TUBE CUTTER

A precision-built tool, 1/8"-1" capacity, for cutting copper, brass, aluminium and thin steel tubings. Strong magnesium alloy casting and steel thread insert guarantee long working life. Press button operation flicks out a reamer blade which returns neatly after use.

FULLY GUARANTEED.

Spare parts for all "JAN" products readily available.

50

## RELIABLE "JAN" PRODUCTS

### ★ STRAP WRENCH



No. 50 (Code 4050) 1/2"-2" Capacity Weight 8 ozs.  
With Alloy Handle and Woven Strap to obviate marking.  
Chrome Plated fittings.

### ★ CHAIN WRENCH

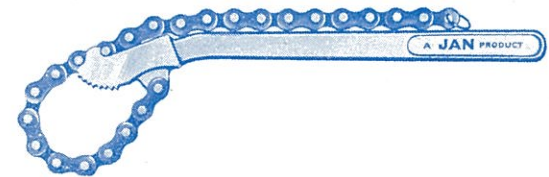

No. 53 (Code 4053) 1/2"-4" Capacity Weight packed 2 Lbs.

51

★ FAST JOINTER

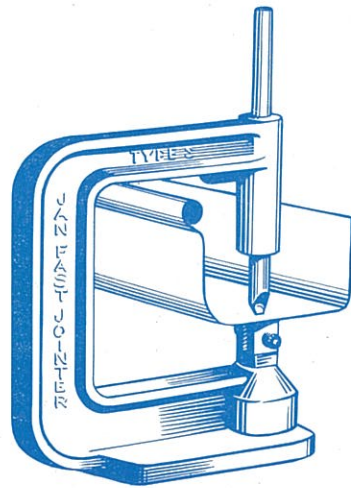

No. 55 (Code 4055) Weight 9 Lbs.

Jan Fast Jointer spouting tool, type "S" considered by Plumbers as the most efficient means of joining spouting.

★ CHAIN PIPE VICE (TOP SCREW)

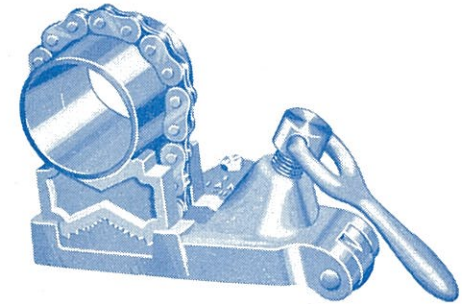

No. 31 (Code 4031) 2" Capacity Weight 8 Lbs.  
No. 32 (Code 4032) 4" Capacity Weight 14½ Lbs.

No more barked knuckles! The Chain Vice with clamp handle above the bench for quicker, easier operation. Screw exerts maximum pressure on the pivoted lever, transferring tremendous pressure on the pipe by medium of the chain. The only pipe vice fitted with fully machined reversible and replaceable heat treated jaws.

★ FOLDING VICE STAND

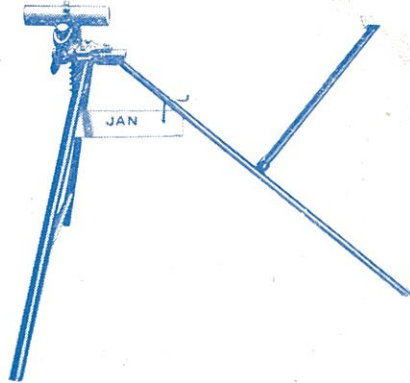

No. 54 (Code 4054)

No. 54/31 (Code 4054-31)  
Stand complete with 2" Jan Chain Vice.

No. 54/32 (Code 4054-32)  
Stand complete with 4" Jan Chain Vice.

Weight - Stand only 31 Lbs.

**PORTABLE FOLDING VICE STAND**

Saves operator's time and effort. Sets up, takes down easily . . . quickly. Extremely rigid and durable, yet weighs only 31 Lbs. All one unit. No loose parts. Has large size vice base for easy mounting of Jan Chain Type or other vices.

FULLY GUARANTEED.

★ UNIVERSAL VEE BLOCK JAWS



No. 48 (Code 4048)

Weight 2¼ Lbs.

A very handy tool for use with conventional engineers vice to facilitate the holding of pipe etc.

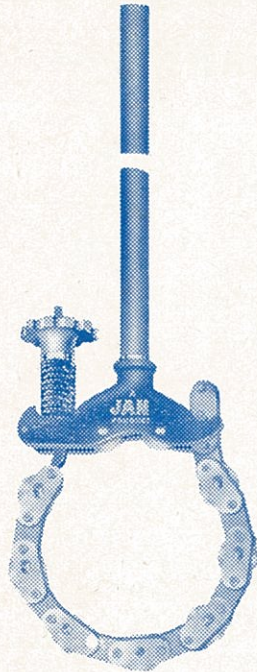

★ LINK TYPE  
CAST IRON  
PIPE CUTTER

No. 51  
(Code 4051)  
Weight 6½ Lbs.

2" - 6" CAPACITY CAST IRON  
PIPE CUTTER

The lightest, fastest and most compact C.I. pipe cutter on the market. By adding links and wheel units, cutting capacity may be increased to handle pipes up to 12" diameter.

FULLY GUARANTEED.

51/6 Spare wheels available (Packed in 1 Doz. lots.)