

# MOUNTING HOLES FORGED STEEL UTILITY VICE FIXED BASE

VICE FRONT

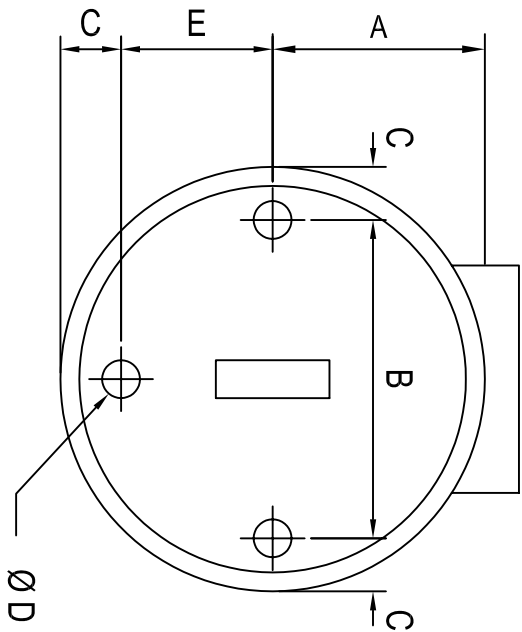

ALL DIMENSIONS ARE IN MM

PART NO.	SIZE	A	B	C	D	E
60420	100mm	57	83	15	9	40
60421	125mm	80	110	18	13	38
60422	150mm	83	150	20	15	60
60423	175mm	105	150	20	15	60

